



LEAHUA



Li-Master 9

LH-L034A

This manual contains important information.
Please read before operating fixture.

Guangzhou Leahua Lighting Technology Ltd

[http:// www.leahualighting.com](http://www.leahualighting.com)

Index

1. Safety Instructions	2
2. Appearance	3
3. Technical Specifications	4
4. Operation	8
4.1 Front panel operation	8
4.2 Board instruction	8
5. DMX Protocol	15
6. Maintenance & Cleaning	17
6.1 Cleaning	17
6.2 Lubrication	17
6.3 Troubleshooting	17

Accessories

Name	Quantity	Remark
User manual	1pc	
Power cable	1pc	
DMX signal cable	1pc	

1. Safety Instructions

WARNING!!! To reduce the risk of fire, electric shock, or injury to persons, follow these important safety instructions:

- Check before use

Before operation, inspect the fixture for transportation damage. Do not use it if damaged. Unauthorized modification or improper use is not covered by warranty.

- Environment

The fixture is IP20-rated, suitable for indoor/outdoor use, and can operate in humid or dusty areas. Keep it away from excessive heat, fire, vibration, electrical surges, and strong light.

- Personnel & operation

Installation and operation must be performed by qualified personnel. Ensure all covers are securely in place, wear protective gear, and do not open the housing or attempt self-maintenance.

- Optical safety

Do not look directly into the light source. Do not use with dimmer packs. Maintain a minimum distance of 20 m from illuminated surfaces, and replace damaged optical components immediately.

- Electrical safety

Ensure correct voltage, proper grounding, and compliant power cords. Do not use damaged cables, and unplug by holding the plug. Avoid operating under heavy rain or extreme humidity, and avoid frequent on/off switching.

- Installation

Use the safety cord through the provided safety holes. Keep at least 50 cm ventilation clearance and do not mount on flammable surfaces or aim the beam at combustible objects (minimum 20 m).

- Temperature & normal conditions

Housing temperature may reach 45 – 75° C during operation. Slight smoke or odor may occur at first ignition and is considered normal.

2. Appearance

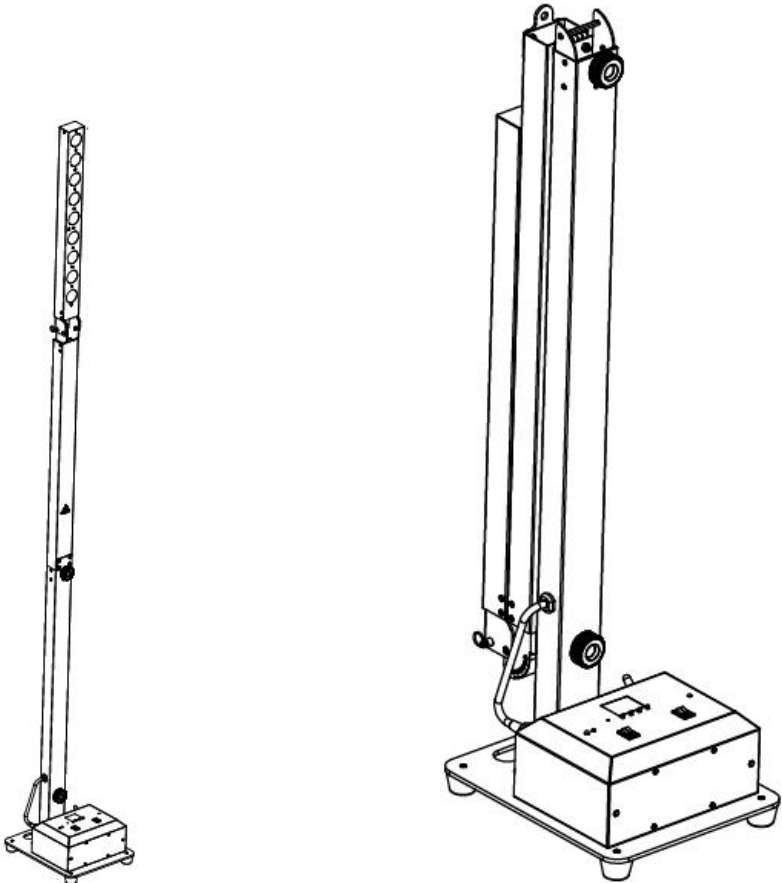

3. Technical Specifications

Power

Input Voltage: AC 100-240V/ 50-60Hz

Power Consumption: 90W

Light source

Light Source: 9×10W RGBWA+UV LED

Life expectancy: About 20000 hours (factory rated)

Beam Angle

Beam Angle: 25°

Field Angle: 50°

Control

Display: OLED display

Control Channel: 2/ 6/ 10CH

Control Mode: DMX512, master-slave, auto, sound, wireless, wifi (app), remote, RDM

Other Function

Smart foldable pole for easy transport and setup

Dimming/Strobe

Dimming: 0-100% linear dimming system

Strobe: 0-24 F.P.S, speed adjustable

Housing

Housing: Aluminum alloy

Protection rate: IP20

Connection

Power Connection: Powercon in/ out

Signal Connection: DMX 3-pin in/ out

Working temperature

Working temperature: -10°C - 45°C

Product dimensions

250×300×2325mm

Net weight

10.77kg

Battery

Battery Type: Lithium ion

Battery Power: 300Wh; 12V, 25Ah

Battery Charge Time: About 6 hours (full power)

Battery Life: About 4 hours (all on), 24 hours (single color)

Dimensions:

Folded dimensions / Unfolded dimensions

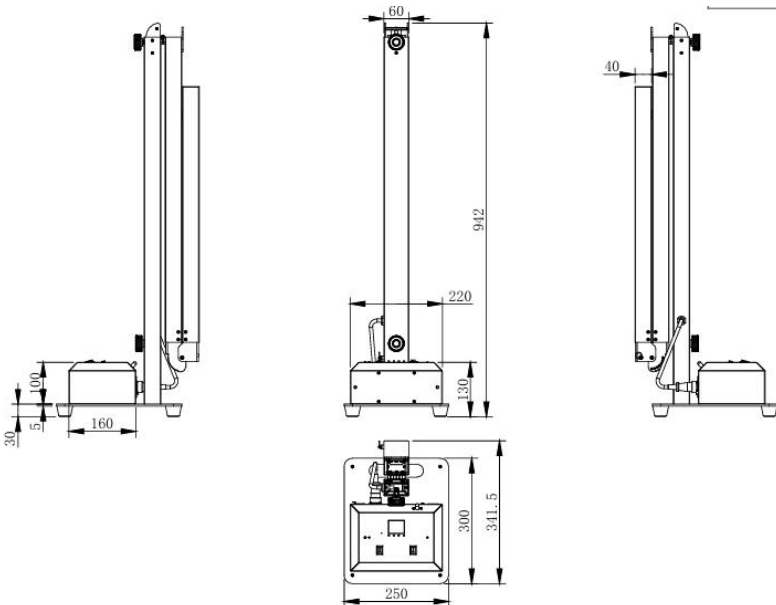

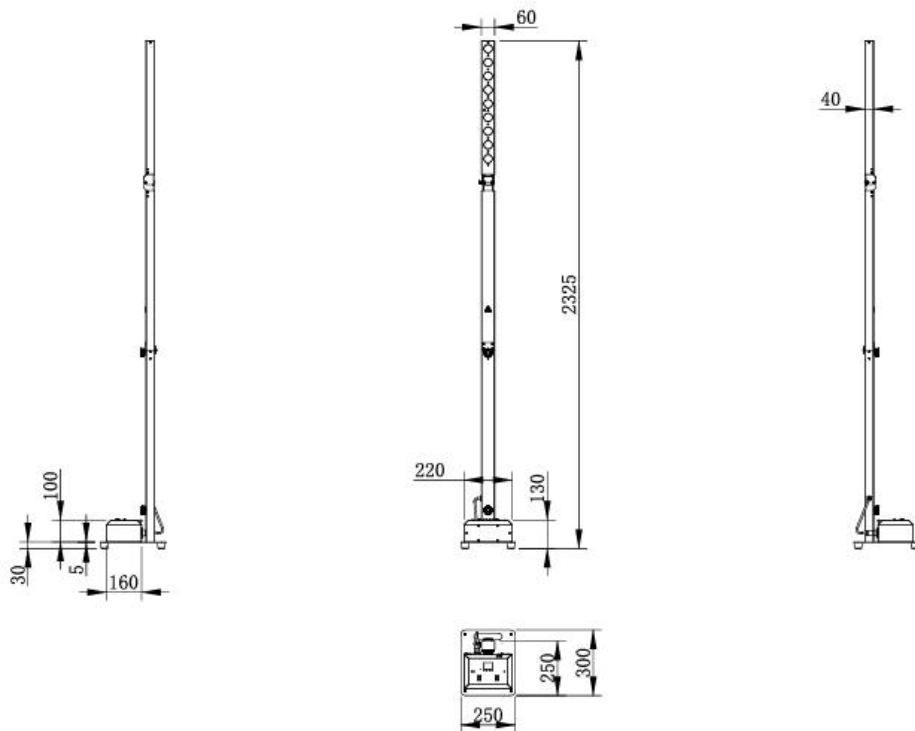

Light output:

Li-Master 9

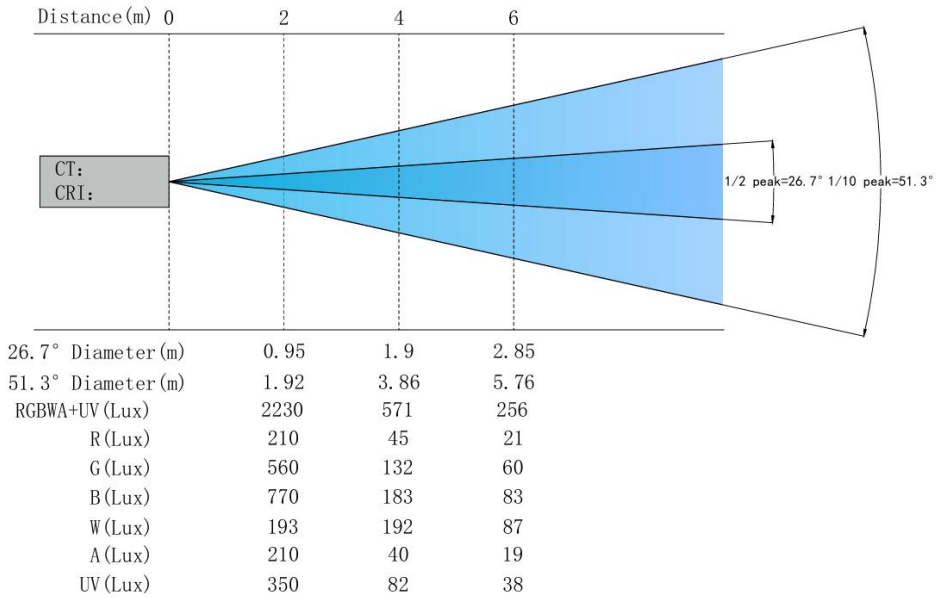

4. Operation

4.1 Front panel operation:

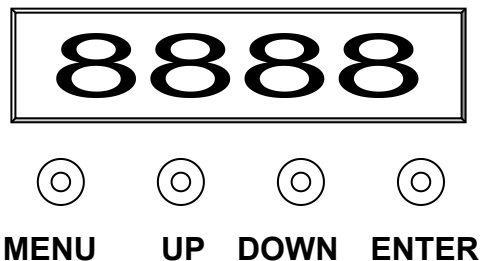

MENU	Main menu function selection/exit submenu
UP	Select the previous menu/parameter increment
DOWN	Select the next menu/parameter decreasing
ENTER	Recognize the selected function / enter the next menu

Method of operation

Switch machine operation:

When the power is off, press and hold the MENU button, after 3 seconds, the display will light up and be in the power-on state, and you can perform the required function operations.

When the power is on, press and hold the MENU button, after 3 seconds, the display will turn off and the power will be cut off.

"Choose Pattern" selection pattern

Select "Choose Pattern" and press the ENTER button to confirm. The display will show the corresponding function menu. Such as static

color, macro function color mixing, performance mode, voice control mode. Use the UP/DOWN button to select among the functions. If you press the ENTER button, the display will enter the next menu item, and if you press the Menu button, you will exit to the previous menu mode. The parameters will be automatically saved after selection.

"User Settings" user settings

Select "User Settings" (user console mode setting), press the ENTER button to confirm, the display will enter the channel options, use the UP/DOWN button to select "6Ch" (6 channel mode), "10Ch" (10CH channel mode) , When you press the ENTER button again, the menu will automatically jump to the "DMX512" address setting mode. With the UP/DOWN button, you can adjust the address code you need to set between 1 and 512. After you select it, the parameters will be automatically saved. If you press the ENTER key again, it will return to the main interface. When DMX512 signal is received, the interface will display "Connection" prompt. If the DMX512 signal is disconnected, the interface will display "Disconnect" prompt. If you press the ENTER or MENU button, the display will exit to the previous menu mode.

"Slave" slave mode

Select "Slave" (slave mode), press the ENTER button to confirm, "Slave Mode!" will be displayed. Indicates that it has entered the slave receiving mode state. After selection, the parameters will be

automatically saved.

When the host signal is received, the interface will display "Connection" prompt, if the host signal is disconnected, the interface will display

"Disconnect" prompt, if you press ENTER Or press the MENU button, the display will exit to the previous menu mode.

"System Settings" system settings mode

Select "System Settings" (system settings mode), press the ENTER button to enter the next menu, use the UP/DOWN button to select different

settings among the setting functions, press the ENTER or MENU button, the display will exit to the previous Level menu mode.

DMX512 console control mode

In the "User Settings" interface, press the ENTER button to confirm.

"Channel" (channel mode) is displayed on the screen, use the UP/DOWN button to select "6Ch" (6 channel mode) or "10Ch" (10CH channel mode) as needed, press the ENTER button to automatically jump to "DMX512"

(DMX512 address) Code setting), use the UP/DOWN button to adjust the address code you need to set between 1 and 512, and then you can receive the DMX512 console control signal.

If you want to use this function, please refer to the following diagram to set the DMX512 addresses of the first 4 fixtures:

6CH mode: 1: A001, 2: A007, 3: A015, 4: A022

10CH mode: 1: A001, 2: A011, 3: A023, 4: A035

Master and Slave machine built-in program control

When multiple fixtures are connected in the main and auxiliary mode, except for the first one, select "Slave" (slave mode) for the other lamps behind, press the ENTER button to confirm, and "OK!" will be displayed.

Indicates that it has entered the slave receiving mode state. After selection, the parameters will be automatically saved. When the host signal is

received, the interface will display a "Connection" prompt. If the DMX512 signal is disconnected, the interface will display a "Disconnect" prompt. If you press ENTER Or press the MENU button, the display will exit to the previous menu mode. The first light fixture is used as the host, and all

performance modes can be selected, and the auxiliary unit will be controlled by the host to perform the same actions.

WiFi Operation mode

In the "User Settings" interface, press the ENTER button, use the

UP/DOWN button to select "WiFi Mode" (WIFI mode), press the

ENTER button, the WiFi icon will appear, indicating that the WiFi

module has been turned on, and you can use your mobile phone at

this time Set up for

connection control. Open the phone settings function, find the wireless and

network WLAN items, connect the device with the name of LED_XXX, as shown in the figure



When the connection is successful, exit the mobile phone function settings and open the “Led LAMP” application software, then the corresponding mode operation can be carried out. App interface and mobile phone operating system may be different.

4.2 Board instruction:

Menu	Item1	Item2	Item3
"Choose Pattern"	"Static"	(Color)	(Dimming)

		RED	0-255
		GREEN	0-255
		BLUE	0-255
		WHITE	0-255
		AMBER	0-255
		PURPLE	0-255
		STROBE	0-20
	"Macro"	1-32	
			(Speed)
	"Show"	"AUTO"	0-20
		"FADE"	0-20
		"SNAP"	0-20
		"R-STRO"	0-20
		"G-STRO"	0-20
		"B-STRO"	0-20
		"A-STRO"	0-20
			(Sensitivity)
	"Sound"	"SOUND1"	0-100
		"SOUND2"	0-100
		"SOUND3"	0-100
			(Options)
"User Settings"	" Channel"	006/010	
			(Addressed)
	" DMX512"	001-512	
			(Mode)
	" Slave"	OK	
	" WiFi"	WiFi Icon	

"System Settings"	"1.white Balance"	(Color)	(Brightness)
		RED	127-255
		GREEN	127-255
		BLUE	127-255
		WHITE	127-255
		AMBER	127-255
		PURPLE	127-255
	"2.Show Battery Icon"	YES/NO	
	"3.Display Sleep"	Open/5Sec/10Sec/15Sec	
	"4.Autolock"	YES/NO	
	"5.FAN Control"	Auto/High/Medium/Low	
	"6.Infrared Setting"	ON/OFF	Remote control
	"7.Wireless Setting"	ON/OFF	
"8.Factory Reset"	Password[----]		
"Informations"	"1.LED"	(Temperature)	0-99°C
	"2.WORK"	(Hours)	001-999
	"3.SOFT"	(Version)	xxx
	"4.LEVEL"	(Percent)	10-100

5. DMX Protocol

6CH	10CH	Value	Function
	1	0-255	Master dimmer ,CH9(0~9)
	2	0-9	Shutter close
		10-255	Shutter open, from slow to fast
1	3	0-255	Dimmer intensity from 0% to 100%- Red
2	4	0-255	Dimmer intensity from 0% to 100%- Green
3	5	0-255	Dimmer intensity from 0% to 100%- Blue
4	6	0-255	Dimmer intensity from 0% to 100%- White
5	7	0-255	Dimmer intensity from 0% to 100%- Amber
6	8	0-255	Dimmer intensity from 0% to 100%- Purple
		0-10	Dimmer mode
		11-30	Color mode: CH10 choose color
		31-50	Color Jump mode : CH10 control speed
		51-70	Color fade mode: CH10 control speed
		71-90	Color pulse mode: CH10 control speed

		91-110	Red On + Shutter: CH10 control speed
		111-131	Green On + Shutter: CH10 control speed
9		132-151	Blue On + Shutter: CH10 control speed
		152-171	Amber On + Shutter: CH10 control speed
		172-191	Purple On + Shutter: CH10 control speed
		192-211	Sound mode
		212-231	Sound mode + Color fade mode
		232-255	Sound mode + Strobe
10	0-255	CH10 function decided by CH9	
		Color control when CH9 on value10-29	

6. Maintenance & Cleaning

Regular maintenance is essential to ensure optimal performance and extend the service life of the fixture.

6.1 Cleaning

Disconnect the unit from power before any cleaning work.

Use a soft, lint-free cloth slightly dampened with mild detergent to clean the exterior surfaces.

Gently remove dust from ventilation slots, optical lenses, and cooling components using compressed air or a soft brush.

Avoid using solvents, alcohol, or abrasive materials that may damage the housing or optical elements.

6.2 Lubrication

This fixture is designed with sealed or maintenance-free moving parts. Under normal operating conditions, no additional lubrication is required.

If abnormal noise or movement resistance is observed, contact qualified service personnel before applying any lubricant.

6.3 Troubleshooting

If the fixture does not power on, verify the power supply, cables, and connectors.

For control issues, check DMX addressing, cable integrity, and ensure proper 3-pin/5-pin XLR connections.

Overheating or unexpected shutdown may indicate blocked ventilation; inspect and clean air inlets and outlets.

If problems persist after basic checks, discontinue use and contact authorized service technicians.



LEAHUA

Guangzhou Leahua Lighting Technology Ltd

Rm 1004, Building A
Baiyun Lake Future Technology Center
No,1 Xinghu Street, Shimen, Baiyun district
Guangzhou 510440, China
